

Quality Line is a complete series of marine accessories. Each product is carefully selected and tested to meet the exacting demands you place on marine equipment.

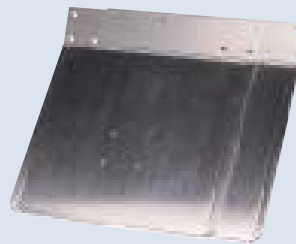

QL bow and stern thrusters
- combining safety and comfort!

QL bow and stern thrusters offer the solution to many difficult situations, for example

- passing through tight locks
- manoeuvring in crowded marinas
- docking in strong side winds or strong currents
- getting close enough to go ashore in bays, along cliffs or archipelagos

QL bow and stern thrusters are designed to give the maximum possible power for the lowest possible electricity consumption.

They are ideal for use on boats where space is limited. QL bow and stern thrusters are suitable for leisure boats from 6 to 22 m, as well as smaller working boats.

The range of bow and stern thrusters has been developed and extended to include thrusters that incorporate the latest research findings and results of extensive trials in ship design laboratories and at sea. BP800 is available as a version for a 10 mm tunnel wall thickness, in accordance with Lloyd's requirements for classified boats. QL bow and stern thrusters are approved to 94/25/EEC.

The very efficient transfer of energy from motor to propeller, combined with the hydrodynamically shaped lower gear housing make QL bow and stern thrusters the most powerful in their respective power ranges. The design of the gear housing and propellers permits a large volume of water to pass through the tunnel, which in turn gives more power in relation to electricity consumption. BP300 and BP450 have gear housings of acid-resistant steel with smaller dimensions, which therefore provide even better throughput. All propellers (except the BP300) come in High Speed specification, i.e. they are manufactured from glass fibre reinforced acetel. A built-in electronic delay prevents damage to the motor through immediate switching of the direction of rotation.

BP450, BP800 and BP1200 have twin, counter-rotating propellers which give maximum propulsion per kW of consumed power.

This also reduces the risk of cavitation, as well as drive noise. The bow thrusters use a drive belt between motor and drive, which further reduces noise level and hence motor wear. The motor is positioned above the propeller tunnel, which ensures very small overall dimensions.



BP300 2508



BP600 2510

BP300
Part no. 41 100436-9
Thrust 12 V
294 N
Motor output 2 kW (2.7 hp)
Motor pos. in rel. to prop. vertical
Tunnel diam. internal 132 mm
Gear housing acid-resistant steel

No. of propellers 1
Max. boat length 26 foot

BP600
Part no. 41 100438-5 12 V
Part no. 41 100439-3 24 V
Thrust 589 N
Motor output 3 kW (4 hp)
Motor pos. in rel. to prop. vertical
Tunnel diam. internal 185 mm
Gear housing bronze
No. of propellers 1
Max. boat length 39 foot

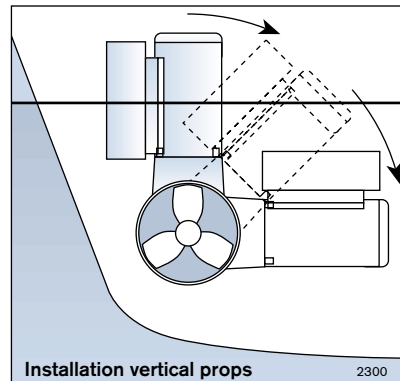

Installation vertical props 2300

Where space is restricted, QL bow thrusters can be installed at any angle from 0 to 90 degrees.

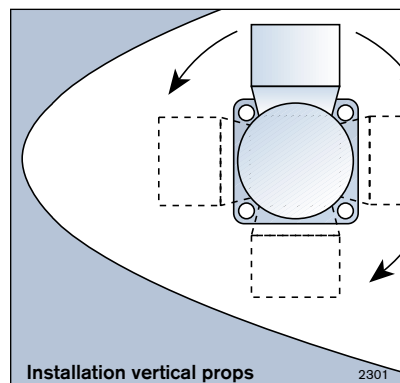

Installation vertical props 2301

QL bow thrusters can be installed with the connection box facing the most convenient direction.

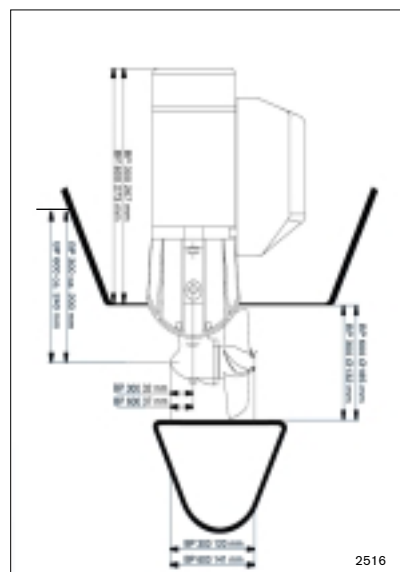

2516



BP450

2509

BP450

Part no. 41100437-7 12 V
 Part no. 41100455-9 24 V
 Thrust 432 N
 Motor output 3 kW (4 hp)
 Motor pos. in rel. to prop. vertical
 Tunnel diam. internal 132 mm
 Gear housing acid-resistant steel
 No. of propellers 2
 Max. boat length 31 foot

BP800V

Part no. 41100447-6 12 V
 Part no. 41100448-4 24 V
 Thrust 785 N
 Motor output 5 kW (7 hp)
 Motor pos. in rel. to prop. vertical
 Tunnel diam. internal 185 mm
 Gear housing bronze
 No. of propellers 2
 Max. boat length 50 foot

BP800

Part no. 41100391-6 12 V
 Part no. 41100392-4 24 V
 Thrust 785 N
 Motor output 5 kW (7 hp)
 Motor pos. in rel. to prop. horizontal
 Tunnel diam. internal 185 mm
 Gear housing bronze
 No. of propellers 2
 Max. boat length 50 foot

BP800/10

Part no. 41100449-2 12 V
 Part no. 41100450-0 24 V
 Thrust 785 N
 Motor output 5 kW (7 hp)
 Motor pos. in rel. to prop. horizontal
 Tunnel diam. internal 185 x 10 mm
 Gear housing bronze
 No. of propellers 2
 Max. boat length 50 foot

BP1200

Part no. 41100393-2 24 V
 Thrust 1177 N
 Motor output 7 kW (10 hp)
 Motor pos. in rel. to prop. horizontal
 Tunnel diam. internal 250 mm
 Gear housing bronze
 No. of propellers 2
 Max. boat length 70 foot



BP800V

2511

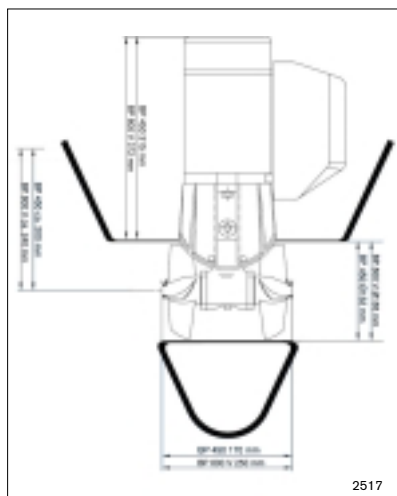

2517

TUNNELS:

Tunnel, 5 mm thickness
 Diam.: 132 mm
 Length = 750 mm
 Length = 1000 mm

Part no.
 41100411-2
 41100412-0

Diam.: 185 mm
 Length = 750 mm
 Length = 1000 mm
 Length = 1500 mm
 Length = 1750 mm

Part no.
 41100053-2
 41100054-0
 41100055-7
 41100056-5

Diam.: 250 mm
 Length = 750 mm
 Length = 1000 mm
 Length = 1500 mm
 Length = 1750 mm

Part no.
 41100217-3
 41100218-1
 41100219-9
 41100220-7

Tunnel, 10 mm thickness
 Diam.: 185 mm
 Length = 750 mm
 Length = 1000 mm
 Length = 1500 mm
 Length = 1750 mm

Part no.
 41100451-8
 41100452-6
 41100453-4
 41100454-2



BP800

2542



BP1200

2543

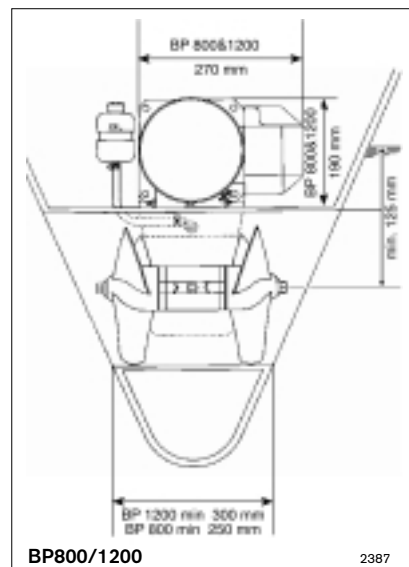

BP800/1200

2387

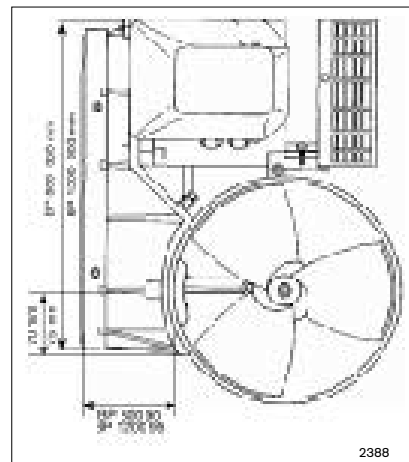

2388

Connection box, alternative installations



Installed in combination with a bow thruster the stern thruster improves boat manoeuvrability and greatly simplifies berthing, even with larger boats. QL stern thrusters are recommended for boats with in-board engines, (single installation) with a conventional propeller shaft. They are installed at the stern, with the motor inside the hull and the propeller tunnel outside the transom. The tunnel has a flared inlet and outlet in order to improve flow. The tunnel is included in the kit.

SP600

Part no. 41100442-7	12 V
Part no. 41100443-4	24 V
Thrust	589 N
Motor output	3 kW (4 hp)
Motor pos. in rel. to prop.	vertical
Tunnel diam. internal	185 mm
Gear housing	bronze
No. of propellers	1
Max. boat length	39 foot



SP800

Part no. 41100444-3	12 V
Part no. 41100445-0	24 V
Thrust	785 N
Motor output	5 kW (7 hp)
Motor pos. in rel. to prop.	vertical
Tunnel diam. internal	185 mm
Gear housing	bronze
No. of propellers	2
Max. boat length	50 foot



SP1300

Part no. 41100446-8	24 V
Thrust	1275 N
Motor output	7 kW (10 hp)
Motor pos. in rel. to prop.	vertical
Tunnel diam. internal	250 mm
Gear housing	bronze
No. of propellers	2
Max. boat length	70 foot

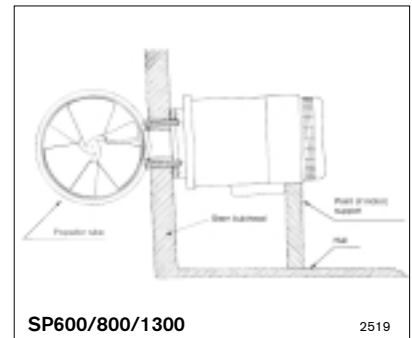

Note! Not to be installed in petrol engine rooms.





Installation tool

2515



2386

INSTALLATION TOOL

A special tool is available to simplify measurement, centring, marking and hole-cutting. Ask your Volvo Penta dealer about this tool.

Bow thrusters can be installed in tunnels of polyester or steel, which means that they will fit most hull types.

OIL FOR BOWTHRUSTERS.

Part no. 41100129-0. Oil for bow- and sternthrusters, 0.25 litres.

Zinc anode

Description	Part no
BP/SP600	41100098-7
BP/SP800	41100276-9
BP1200/SP1300	41100311-4

Zinc anode is not needed for BP300/450 since the lower house is constructed of acid-resistant, stainless steel

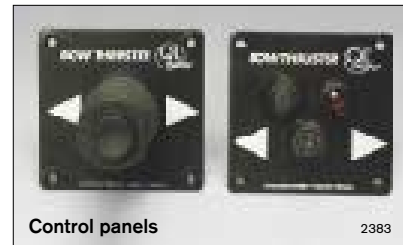

Control panels

2383

NEW!



Touch panel

2798



Control panel

2544

CONTROL PANEL

QL bow and stern thrusters are operated from a separate control panel. Choose between joystick, rocker switch and touch panel, the two last ones being particularly suitable for sailboats where sheets and halyards could snag on a joystick. If the existing engine controls offer a "power trim" function the bow thruster can be operated from the switch on the control handle.

CONTROL PANEL WITH JOYSTICK

Part no. 41100120-9, includes 8 m cable. Operates on 12V or 24V.

PANEL WITH ROCKER SWITCH

Part no. 41100216-5. Operates on 12V or 24V.

TOUCH PANEL

Part no. 41100617-4. With touch-sensitive switch, indirect lighting, On/Off button, includes 8 m cable. Operates on 12V or 24V.

CONTROL PANEL FOR BOW AND STERN THRUSTERS

Control panel for bow and stern thrusters. For boats with both bow and stern thrusters, this double control panel will make it possible to handle both thrusters with one hand.

Part no	Voltage
41100605-9	12V
41100613-3	24V

Fuse

Description	Volt	Fuse A	Part no. incl holder	Part no. excl holder
BP300	12 V	200 A	41100600-0	41100601-8
BP450 BP/SP600	12/24 V	300 A	41100052-4	41100180-3
BP/SP800,	24 V	355 A	41100604-2	41100603-4
BP/SP800	12 V	425 A	41100403-9	41100402-1
BP/SP1200/SP1300	24 V	425 A	41100403-9	41100402-1

QL - Bow and stern thrusters

Description	Part no.	Motor supply	Drive force	Motor output	Motor position rel. to prop.	Tunnel diam., internal	Gear housing	No. of propellers	Max. boat length, ca
BP300	41100436-9	12 V	294 N	2 kW (2.7 hp)	vertical	132 mm	Acid-resistant steel	1	26 foot
BP450	41100437-7	12 V	432 N	3 kW (4 hp)	vertical	132 mm	Acid-resistant steel	2	31 foot
BP450	41100455-9	24 V	432 N	3 kW (4 hp)	vertical	132 mm	Acid-resistant steel	2	31 foot
BP600	41100438-5	12 V	589 N	3 kW (4 hp)	vertical	185 mm	Bronze	1	39 foot
BP600	41100439-3	24 V	589 N	3 kW (4 hp)	vertical	185 mm	Bronze	1	39 foot
BP800	41100391-6	12 V	785 N	5 Kw (7 hp)	horizontal	185 mm	Bronze	2	50 foot
BP800	41100392-4	24 V	785 N	5 Kw (7 hp)	horizontal	185 mm	Bronze	2	50 foot
BP800V	41100447-6	12 V	785 N	5 Kw (7 hp)	vertical	185 mm	Bronze	2	50 foot
BP800V	41100448-4	24 V	785 N	5 Kw (7 hp)	vertical	185 mm	Bronze	2	50 foot
BP800/10	41100449-2	12 V	785 N	5 Kw (7 hp)	horizontal	185 x 10 mm	Bronze	2	50 foot
BP800/10	41100450-0	24 V	785 N	5 Kw (7 hp)	horizontal	185 x 10 mm	Bronze	2	50 foot
BP1200	41100393-2	24 V	1177 N	7 kW (10 hp)	horizontal	250 mm	Bronze	2	70 foot
SP600	41100442-7	12 V	589 N	3 kW (4 hp)	vertical	185 mm	Bronze	1	39 foot
SP600	41100443-4	24 V	589 N	3 kW (4 hp)	vertical	185 mm	Bronze	1	39 foot
SP800	41100444-3	12 V	785 N	5 kW (7 hp)	vertical	185 mm	Bronze	2	50 foot
SP800	41100445-0	24 V	785 N	5 kW (7 hp)	vertical	185 mm	Bronze	2	50 foot
SP1300	41100446-8	24 V	1275 N	7 kW (10 hp)	vertical	250 mm	Bronze	2	70 foot



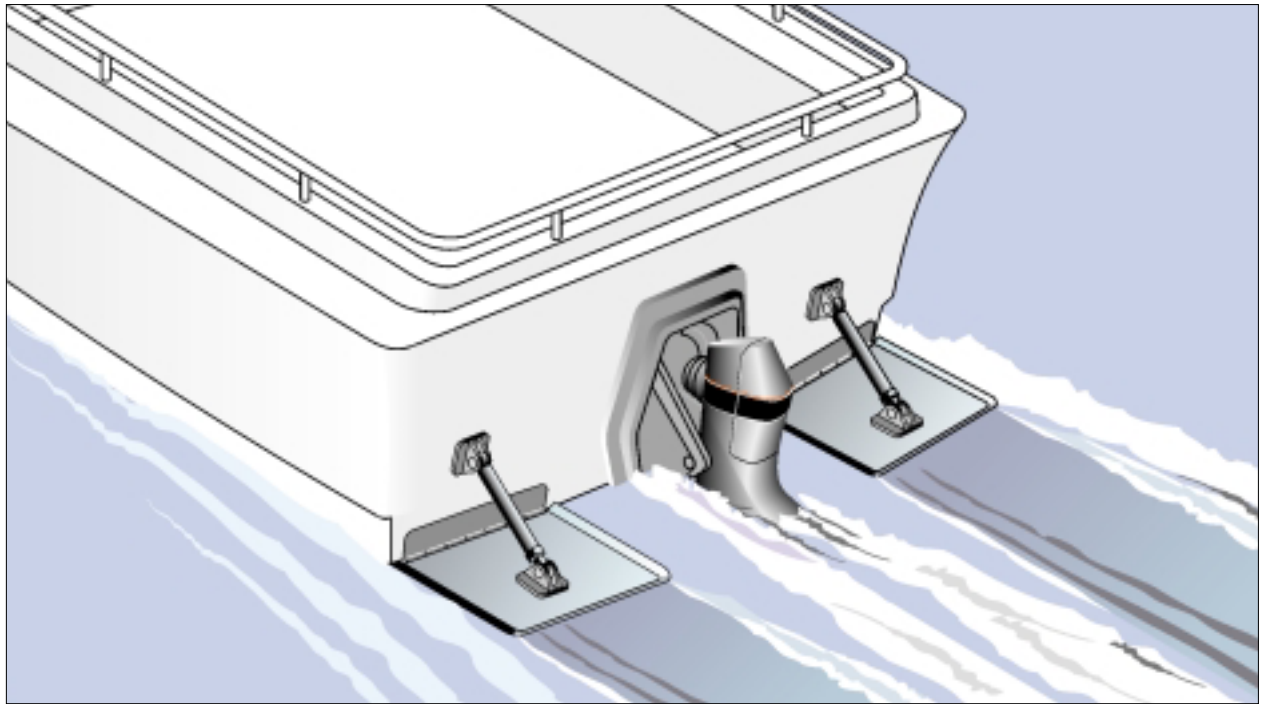

Trim tabs

2503

Quicker to plane. Smoother ride. Better visibility. Lower fuel consumption. The advantages of trim tabs are obvious and ensure a safer and more comfortable journey.

The trim tabs in Volvo Penta's QL series are constructed from high quality, acid-resistant stainless steel and do not require a zinc anode.

They are easily operated by means of push-button switches and the position of the trim tabs is precisely controlled by means of hydraulics.

QL Trim tabs are easy to install and are bolted securely from the outside – alignment is very simple. The single cable connecting the pump unit to the control panel is colour-coded for reliable installation.

For a complete trim tab system the following are needed: Pump kit (including cylinders) and trim tabs of suitable size. The kits are complete and include control panel, all connecting cables, hydraulic hoses and biodegradable hydraulic oil. Optional accessories include a trim tab indicator that shows the precise position of each trim tab, additional trim tab instruments and a spray-proof control panel for Flybridge installation.



Pump kit, High performance

2799

NEW!

NEW CYLINDERS – HIGH PERFORMANCE

No more unprotected hydraulic hoses on the stern. By running the hydraulic hoses through the cylinders we have reduced the risk of hose damage, and there are two less holes to make through the stern bulkhead. In addition, installation is much simpler. Also new is the incorporation of a trim indicator in each cylinder, and this is supplied as standard.

The new cylinder kit with built-in indicator will give you full control of the boat's attitude in the water. More powerful cylinders mean that only one per trim tab is required for boats up to 40 feet.

The cables from the indicators are run to a connector box and then to the indicator instrument. There is only one cable from the connector box, which makes connection easier.

PUMP KIT, HIGH PERFORMANCE

Part no.	
41102101-7	12 V single cyl, High Perf.
41102102-5	24 V single cyl, High Perf.
41102103-3	12 V double cyl, High Perf.
41102104-1	24 V double cyl, High Perf.



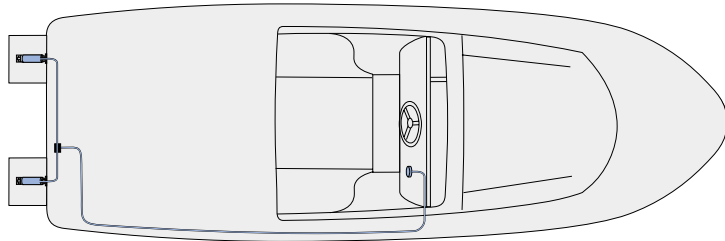

Trim tab indicator

2530

PUMP KIT, STANDARD

Complete kit with pump, 2 or 4 cylinders, cables, hydraulic hoses, control panel and 0.47 l of biodegradable hydraulic oil.

Part no.

41102000-1	12 V single cylinders
41102001-9	24 V single cylinders
41102002-7	12 V twin cylinders
41102003-5	24 V twin cylinders

BIODEGRADABLE HYDRAULIC OIL

0.47 l, part no. 41102100-9.



Pump kit, standard

2502

Part no.	Size	No of cylinders	
		Standard	No of Cylinders High Performance
41102004-3	10" x 8"	single	single
41102005-0	12" x 8"	single	single
41102006-8	12" x 11"	single	single
41102007-6	14" x 11"	single	single
41102008-4	18" x 11"	single	single
41102009-2	24" x 11"	single	single
41102010-0	30" x 10"	single	single
41102011-8	36" x 8"	single	single
41102012-6	40" x 8"	single	single
41102105-8	30" x 10"	twin	single
41102106-6	36" x 8"	twin	single
41102107-4	40" x 8"	twin	*
41102013-4	46" x 8"	twin	twin
41102014-2	50" x 8"	twin	twin
41102015-9	55" x 8"	twin	twin
41102016-7	60" x 8"	twin	twin

* For speeds below 23 knots – single cylinder.
For speeds above 23 knots – twin cylinders

SIZE RECOMMENDATION

Trim tabs.	Boat size
10" x 8"	– 19 feet
12" x 8"	– 20 feet
12" x 11"	20-22 feet
14" x 11"	22-25 feet
18" x 11"	24-29 feet
24" x 11"	28-31 feet
30" x 10"	30-34 feet
36" x 8"	30-34 feet
40" x 8"	33-37 feet
46" x 8"	36-42 feet
50" x 8"	41-47 feet
55" x 8"	46-53 feet
60" x 8"	51-61 feet

To get the best possible results from trim tabs they should be as large as the transom and drive/outboard will permit. There should however be a gap of 5 cm between the drive/outboard and each trim tab at full lock.

TRIM TAB INDICATOR, COMPLETE WITH INSTRUMENTS, CABLES AND CONNECTOR BOX*

41102083-7. Black instrument with white lettering, 8 m cable
41102084-5. White instrument with black lettering, 8 m cable

INDICATOR INSTRUMENT*

41102085-2 Black with white lettering, 6 m cable
41102086-0 White with black lettering, 6 m cable

CONTROL PANEL FOR FLYBRIDGE*

41102046-4 Control panel, spray-proof
41102052-2 Cable, 4 m

EXTENSION CABLES

41102067-0 Cable, 2 m
41102068-8 Cable, 4 m
41102091-0 Cable, 8 m

*Accessories suitable for both 12 V and 24 V Pump kit.



Trim tab indicator

2546



Indicator instrument

2803



Indicator instrument

2804



Control panel

2506

Trim tab system





QL Submersible bilge pumps

2547

A submersible bilge pump increases safety and comfort onboard. QL submersible pumps can handle most bilge pumping situations that can occur and are extremely economical with electrical power.

The whole range of QL bilge pumps has been improved. The pumps have many advantages, including:

- Simpler to dismantle for ease of cleaning. In three easy actions without the use of tools you can remove the pump unit to clean the inside of the pump housing.
- Extremely economical with electrical power in relation to pump capacity.
- Improved water-cooled motor. Bilge water circulates around the pump before being pumped out.
- Versatile bracket for mounting on stringer or transom.
- Spark protected, they can be installed in petrol engine compartments.
- They can be combined with an electronic float switch which automatically starts the pump when there is water in the bilge. When the boat has been pumped dry the sensor automatically switches the pump off. We also offer a range of pumps (Combi-pumps), supplied with an electronic float-switch as standard.

SBP130

A very compact, powerful pump which is ideal for the hard life of working boats. This pump can lift up to 130 litres per minute (to free outlet) and is available for 12 and 24 V.

The motor has double roller bearings, and a mechanical seal virtually eliminates shaft wear. This, together with water cooling, helps to ensure many years of trouble free life with very low power consumption.

SBP45, 55, 65, 75 AND JUNIOR MATE

These small, compact bilge pumps come in five sizes. The SBP models pump 45, 55, 65 and 75 litres per minute respectively, and the Junior Mate pumps 30 litres per minute.

TECHNICAL DATA:

Pump housing	Thermo-plastic resistant to bilge water containing petrol, solvents etc.
Pump impeller	Glass fibre reinforced plastic for maximum durability
Motor shaft	Acid-resistant stainless steel
Filter	Large strainer area to prevent clogging
Cable	Heavy-duty PVC sheathed cable

SBP45, 55, 65, 75 COMBI

Capacity as the standard bilge pumps, these are supplied as standard with an electronic float switch which automatically starts/stops the pump.

BILGE PUMP FOR SHOWER

Part no. 41103010-9. Complete with bilge pump, 12 V, 61l/min, electronic float switch, filter and attachments. Easy to clean.

The bilge pump for shower has three inlets, to enable handling of waste water from more than one tapping point.

Dimensions: Length 290 mm, width 210 mm, height 145 mm



Bilge pump for shower

2549



SBP Panel

2776

SBP PANEL

The bilge pump can also be controlled from the bridge manually or automatically, with help of the QL control panel. It is a three position switch panel in mat black plastic with built-in fuse holder and warning light.

Dimensions: Height 55 mm, width 76 mm, depth 40 mm.

SBP panel	Part no.
12 V	41100009-4
24 V	41100010-2

Pump type	Part no. single	Part no. combi	Max capac. l/min	Hose conn. inch	Voltage V	Amperage Amp	Fuse Amp	Max diam mm	Max height mm
Junior mate	41100000-3	-	30	3/4"	12	2.0	3	115	100
SBP45	41103000-0	41103004-2	45	3/4"	12	2.0	3	70	112
SBP55	41103001-8	41103005-9	55	3/4"	12	2.4	4	70	112
SBP65	41103002-6	41103006-7	65	3/4"	12	3.4	5	70	112
SBP75	41103003-4	41103007-5	75	1 1/8"	12	3.2	5	70	112
SBP130	41103008-3	-	130	1 1/8"/1 1/2"	12	7.5	12	108	177
SBP130	41103009-1	-	130	1 1/8"/1 1/2"	24	4.5	6	108	177



QL MANUAL BILGE PUMP

If there is no electrical power on board you can always rely on the little QL manual bilge pump.

It pumps 0.9 litre per stroke which equals 90 litres per minute at 100 strokes per minute. It can be installed behind a bulkhead or below deck to take up the least possible room. The pump handle is removable, only being fitted to work the pump, which saves more space.

The QL manual bilge pump comes in two versions to suite different installations: For installation through the deck, i.e. vertical installation, or for installation behind a bulkhead –i.e. horizontal.

VERTICAL INSTALLATION

Part no	Hose connection
41103013-3	1 1/2"
41103014-1	1"

HORIZONTAL INSTALLATION

Part no	Hose connection
41103015-8	1 1/2"
41103016-6	1"

TECHNICAL DATA:

Pump housing	Polymer plastic
Pump handle	Anodised aluminium
Shaft	Acid-resistant stainless steel
Width	253 mm
Height	133 mm
Length of handle	285 mm
Hose sizes	1 1/2" or 1"
Max. capacity	90 L at 100 strokes per minute



Manual Bilgepumps

2550

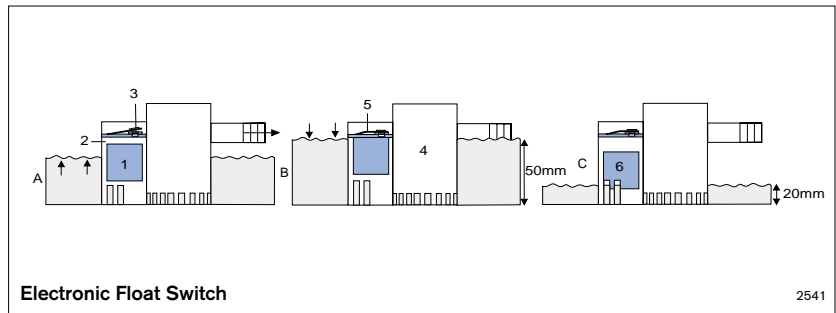

Electronic Float Switch

2541

ELECTRONIC FLOAT SWITCH

Switches on the pump when the water level reaches 50 mm and stops the pump when the level has dropped to 20 mm. Sold separately or as part of the Combi-pump.

Part no.	
41103011-7	12 V
41103012-5	24 V

A. When the bilge water rises the magnet float (1), it floats up and the air in the float house (2) is forced out through the vent hole (3).

B. The magnet float starts the pump (4) when bilge water reaches 50 mm. The valve (5) closes and the magnet float stays in the start position due to vacuum inside the float house.

C. When the bilge water has sunk to level 20 mm, air is let in through the air opening (6) in the float house. The magnet float falls down and cuts off the power.



Float Switch

2309

FS 100 FLOAT SWITCH:

Part no. 41100008-6

When the water level rises, the pump is turned on by a rolling steel ball activating the micro-switch. The FS 100 is easily attached to all bilge pumps in the QL programme (except the manual bilge pumps and Junior Mate) through the clip on the "T-slot"

Dimensions: Width 75 mm, length 155 mm, height 95 mm



2551

With QL domestic water pressure pumps instant running water is available in the galley and shower – at the turn of one or more taps. Domestic water pressure pumps are suitable for both fresh water and sea water. An ideal installation would include one pump for fresh water and one for sea water.

- QL Domestic water pressure pumps are:
- economical with extremely low electrical power consumption in relation to the flow of water
 - safe with spark protected motors
 - reliable and easily serviced with few moving parts
 - problem-free and easy to use. Can be connected to all types of taps. Start and stop automatically when tap is turned on and off. Self-priming and capable of withstanding running dry.

WPS 300, 450

Compact and efficient pumps ideal for small and medium sized leisure craft where low electrical energy consumption is important. A new five-chamber design gives a very even flow of water. These pumps can be installed vertically or horizontally with only three screws. Hose connections or threaded connections that can be adjusted to different positions for optimum installation.

Dimensions: length 227 mm
width 221–146 mm
height 133 mm
weight 0.95 kg

Connections: 1/2" (13 mm) hose connection or 3/8" thread.

WPS 650PS

Designed for heavier duty applications. Particularly suitable in small and medium sized leisure craft where several taps/outlets are often used at the same time. The built-in pressure switch has a newly developed micro-switch and terminal cover which provides protection against corrosion with its subsequent current drainage.

Dimensions: width 178 mm
height 267 mm
weight 2.0 kg.

Connections: 1/2" (13 mm) hose connection or 3/8" thread.

WPS ACCUMULATOR TANK, 1.4 L

Part no. 41100017-7
An accumulator tank for the domestic water system contributes to a more even water pressure and also extends the life of the pump by preventing unnecessary starting and stopping of the pump.

WPS FILTER

Part no. 41100018-5
Recommended for WPS 650PS to protect the pump from impurities in the water. Hose connection 1/2" (13 mm).

MACERATORPUMP – THE PERFECT DISPOSER FOR THE LAVATORY UNIT IN BOATS

The MP 1000 macerator pump takes care of toilet waste. A rotary cutter shreds waste before it is pumped out through the discharge hose. The macerator pump can be connected directly to the bowl discharge outlet or holding tank.

Note! Use unbleached lavatory paper only. Do not run pump dry. Must not be used for continuous duty.

MP 1000

Pump	Voltage	Part no.
MP 1000	12 V	41100029-2

Pre. Bar	Pre. kPa	Flow l/min	Pow. consum., A
0.2	20	37	13 A
0.4	40	34	14 A
0.6	60	30	14 A
0.8	80	28	15 A
1.0	100	22	15 A

Rec. fuse. 20 A 12 A



WPS Accumulator tank

2777

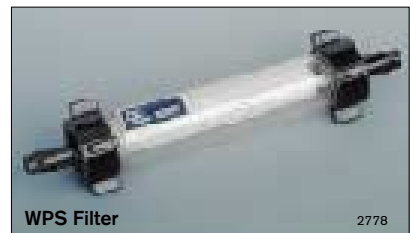

WPS Filter

2778

Body: Phenol plastic (PF)
Impeller: Nitrile
Housing: Thermoplastic polyester (PET)
Shaft: Stainless steel
Seal: Lip seal, nitrile
Engine: 12/24 V DC
Connection: Inlet 38 mm (1.1/2") or 1.1/2" BSP thread
Outlet 25.4 mm (1") hose

Model	Part no.	Voltage V	Capacity max flow l/min	Power consump. A	Fuse A	Head m	System pressure Bar
WPS 300	41100011-0	12	5.0	1.0	3.0	1.5	1.5
WPS 450	41100013-6	12	7.5	1.6	4.0	1.5	1.5
WPS 650PS	41100015-1	12	11.0	5.5	8.0	2.0	1.8
WPS 650PS	41100016-9	24	11.0	3.0	4.0	2.0	1.8

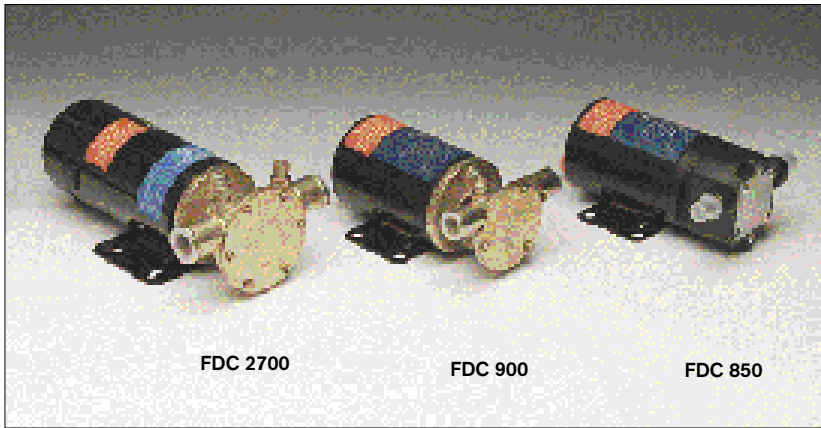

FDC 2700

FDC 900

FDC 850

QL pumps are versatile and therefore ideal as deckwash and bilge pumps, for pumping fresh water and diesel fuel. The combination of a Vac-on-Switch provides extended battery life as well as preventing the pump from running dry. The pumps are self-priming and provide full flow immediately.

Pump	Voltage	Part no.
FDC 850	12 V	41100022-7
FDC 900	12 V	41100024-3
FDC 2700	12 V	41103017-4
	24 V	41103018-2

FDC 850

Pre. Bar	Pre. kPa	Flow l/min	Pow. consump., A	
			12 V	24 V
0.15	15	14.0	7.2	3.5
0.6	60	10.5	7.9	3.8
0.9	90	7.0	8.7	4.2

Rec. fuse. 15 A 8 A

Pump housing: PTMT (thermo-plastic)
 Shaft: Stainless steel
 Pump impeller: Oil resistant material
 Connecting hose: 1/2" (13 mm)
 Motor: 12 Volts DC spark protected
 Dimensions: 172x117x78 mm
 Weight: 1.6 kg

FDC 900

Pre. Bar	Pre. kPa	Flow l/min	Pow. consump., A	
			12 V	24 V
0.15	15	15.3	7.1	3.6
0.6	60	10.9	7.9	3.8
1.2	120	2.7	9.5	4.5

Rec. fuse. 15 A 8 A

Pump housing: Bronze, with connection for Vac-on-Switch
 Shaft: Stainless steel
 Pump impeller: Oil resistant material
 Connection: 3/8" BSP
 Motor: 12 Volts DC spark protected
 Dimensions: 170x100x82 mm
 Weight: 2.0 kg

FDC 2700 NEW!

Bar	kPa	Flow l/min	Pow. consump., A	
			12 V	24 V
0.15	15	46.0	14.2	7.2
0.6	60	34.8	16.5	8.4
1.2	120	11.2	19.6	9.9

Rec. fuse. 25 A 15 A
 Rec. wire size: 4 mm² 2.5 mm²

A new pump with very high capacity in relation to its size and power consumption. The motor has over-heating protection.

The motor can be run continually at up to 5 bar pressure and max. 1 hour at 1 bar (at nominal voltage and room temperature).

Pump housing: Bronze, with connection for Vac-on-Switch
 Shaft: Stainless steel
 Pump impeller: Oil resistant material
 Connection: 1/2" BSP
 Motor: 12/24 Volts DC spark protected
 Dimensions: 202x120x90 mm
 Weight: 3.0 kg

VAC-ON-SWITCH

Part no. 41100028-4

The vacuum switch automatically stops the pump when no liquid remains to be pumped, thereby eliminating the risk of the pump running dry and unnecessary consumption of electrical power. The vacuum switch can be remotely controlled or controlled directly by means of a lever on the switch.



Deck-wash kit

2553

DECK-WASH KIT

Part no. 41103019-0. For easy hosing down the deck. The kit is specially made to fit the FDC2700, and contains a nozzle, pressure reducer and non-return valve. Simple to fit.





QL Water heaters

2554

To have hot domestic water available is one of the things that considerably increases comfort on board. The QL water heater quickly and easily provides enough water at the right temperature for a shower, washing up, shaving etc. by capturing the unwanted heat from the engine cooling system. It is compact, very well insulated and meets the most stringent sanitary requirements.

With a QL water heater you really have a more comfortable life on board.

A QL water heater quickly and easily provides enough water at the right temperature for a shower, washing up, shaving etc. The water in a QL water heater is heated by the energy released from the engine cooling system. Use is thus made of the heat that would otherwise go to waste. The water heater also has a 220 V/800 W immersion heater for connection to on-shore power. An adjustable thermostat cuts off heating at the desired temperature. It has a heater cut-out to prevent boiling.

The water heater is available in 20, 40 and 60 L sizes. The tank is made completely in acid resistant stainless steel, which makes it very suitable for a marine environment. The 1.5 mm thickness and TIG welded joints make the tank very strong and give increased corrosion protection. The design and materials also meet the highest sanitary requirements.

The QL water heater is insulated with foamed polyurethane, a material with millions of air cells which prevent heat loss. The insulation is extra thick to the top of the tank and keeps the water hot a long time after the heater is turned off.

The QL water heater is easily mounted, vertically or horizontally, with stainless steel brackets. To obtain maximum effect the outlet is uppermost, whether installed vertically or horizontally. As an optional extra, a thermostatic mixer is available which reduces hot water consumption and guards against scalding.

TECHNICAL DATA:

Tank, engine piping and connections	Acid resistant, stainless steel, SIS 2343-02, 1,5 mm thick
Immersion heater	Incoloy 800, 800W
Insulation	Self-extinguishing, high performance, foamed polyurethane
Connection type/size	19mm threaded couplings plus connection kit for 16mm
Safety valve	Opens at 4 bar, pressure tested to 5 bar

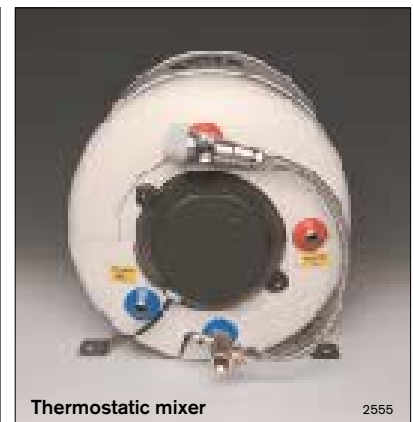

Thermostatic mixer

2555

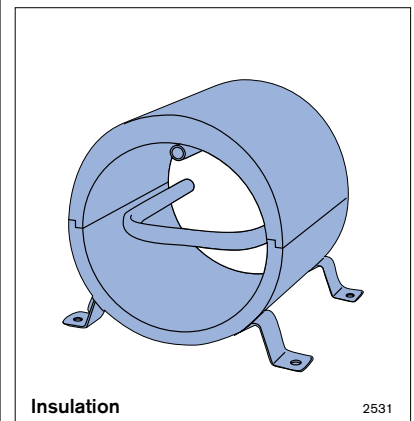

Insulation

2531

Volume	Dia. x length	Weight kg	Immersion element	Part no. 220 V	Part no. 110 V
20L	355 x 410 mm	9	800W	41103500-9	41103511-6
40 L	355 x 670 mm	12	800W	41103501-7	41103512-4
60 L	355 x 900 mm	13	800W	41103502-5	41103513-2

Part no.	Description
41103505-8	Thermostatic mixer for regulating water tap temperature
41103503-3	Overload protection; cuts power load by half when connected to on-shore electricity net in times of peak demand
41103506-6	Magnetic scale remover
41103504-1	1500W/220V Incoloy heating element
41103514-0	1500W/110V Incoloy heating element
41103515-7	800W/110V Incoloy heating element
41103507-4	Hose connection kit for 16 mm cold water



QL Air heater

2800



Nozzle

2801

Air heater

		Part no
10 kW	12 V	41103300-4
10 kW	24 V	41103302-0
5 kW	12 V	41103301-2
5 kW	24 V	41103303-8

Accessories:

	Part no
Hose connector kit, 50 mm:	41103304-6
Hose connector kit, 60 mm:	41103305-3
Hose connector kit, air intake	41103306-1
Switch:	41103307-9
Nozzle, adjustable, black	
50 mm	41103312-9
55 mm	41103313-7
60 mm	41103308-7
Hose, 50 mm	41103309-5
Hose, 55 mm	41103314-5
Hose, 60 mm	41103310-3
Hose, air intake	41103311-1

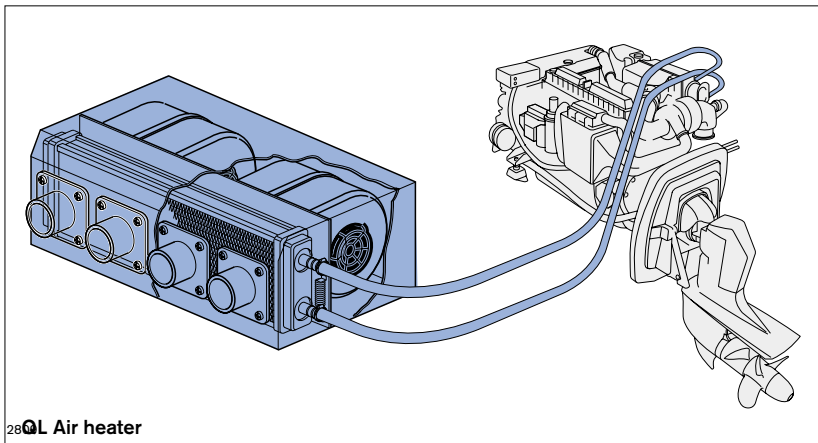

QL Air heater

Now you can quickly make it warm and snug onboard. The QL Air Heater changes even the bitterest of climates onboard to give you a warm, dry and comfortable atmosphere, and you avoid frosted or misty windows.

The QL Air Heater extracts heat from the engine's cooling system, which would otherwise be wasted, and transfers it into the cabin. A fan circulates air through a heat exchanger, which is heated by the engine cooling system. The Air Heater makes it possible to make use of the engine closed-circuit cooling system without additional water piping and radiators. Transferring the heat through a heat exchanger allows the heated air to be quickly sent to where it's needed most. For example to defrost/demist the windshield, or warm up the cabin or control position. Four outlets are supplied that can be connected with air hoses. The standard outlets are 55 mm diameter. The airflow can be set at three different speeds.

The QL Air Heater is highly efficient and can be installed vertically or horizontally. Its compactness makes it easy to locate anywhere. The selection of materials; stainless steel for the casing and copper/brass for the heat exchanger, ensures long service in a harsh onboard atmosphere.

The QL Air Heater comes in two sizes; 5 and 10 kW. Available for 12 V or 24 V supply, it consumes very little power. Its low noise level is another advantage. The Air Heater can be installed above the engine and any air trapped in the coolant can be released through a separate bleed valve.

Optional extras include air hoses, hose connections and various types of air valves.

PRODUCT DATA:

Output:	10kW/5kW
Power supply:	12V/24V
Capacity (free flow):	550m ³ /330m ³ /hour at max. speed
Fan:	3 speed
Casing:	Stainless steel
Heat exchanger:	Copper/Brass
Weight:	6.6 kg/5.1 kg
Dimensions:	Dimensions: 347 x 160 x 236 mm/ 230 x 160 x 236 mm
Fan type:	radial
Water connection:	16 mm

Air heater

		10 kW		5 kW	
		12 V	24 V	12 V	24 V
Power consumption:	Max. effect	11.7 A	6.2 A	8.3 A	4.3 A
	Medium effect	7.4 V	4.8 A	5.9 A	3.6 A
	Low effect	5.6 A	3.9 A	4.7 A	3.1 A
Noise	Max. effect	69 dB		67 dB	
	Medium effect	65 dB		64 dB	
	Low effect	63 dB		62 dB	





QL Fuel decontaminator

2793

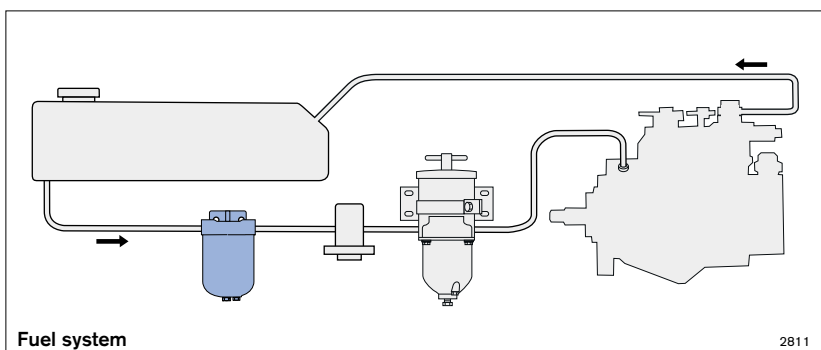

Fuel system

2811

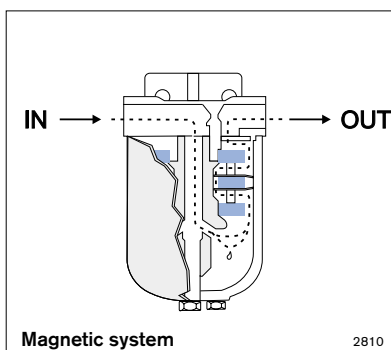

Magnetic system

2810

Diesel fuels often contain micro organisms. When temperature and water content is in harmony the microbes can grow uncontrolled giving you problems with a clogged fuel system and restricted fuel flow.

The engine is not receiving the fuel flow needed to operate properly and you might even risk that the engine stops suddenly. In severe cases there is also the possibility of heavy wear on injector nozzles and injection pump.

The QL fuel decontaminator will help you control the microbial contamination in your fuel. The return flow, already cleaned by the QL fuel decontaminator, will gradually reduce the micro organisms to a minimum.

The QL fuel decontaminator works through a patented magnetic system. When the fuel passes through a system of magnets the micro organisms are killed and broken down to small particles that easily pass through the fuel filter and then burn in the engine combustion.

The QL fuel decontaminator is installed between the tank and the fuel filter. Once installed, it works without any further attention.

Correctly installed, before the fuel return feed, it will also clean the content in the fuel tank. In this way the return feed recirculates fuel back to the fuel tank via the fuel decontaminator, and up to 97% of the micro organisms are broken down each time it passes through. The QL fuel decontaminator offers a permanent solution to the problem of micro organisms in the fuel.

Material: Aluminium

Active components: 3 permanent magnets

The QL fuel decontaminator comes in three sizes:

Part no	Capacity	Connection
41103600-7	Max 140 l/hour	1/4" NPT (nipple included) 1)
41103601-5	140-500 l/h	1/2" NPT 2)
41103602-3	500-1000 l/h	1/2" NPT 2)

1) Incl. 2 nipples 1/4" NPT for 5/16" fuel hose. For connection to 3/8" fuel hose two nipples, part no. 834781-7 are required.

2) For connection to 5/16" fuel hose two nipples, part no. 479954-0 and 2 nipples, part no. 855207-7 are required. For connection to 3/8" fuel hose two nipples, part no. 479954 and two nipples, part no. 834781-7 are required.

Note! The l/hour figures refer to the fuel flow to the engine. The return feed from the injection pump to the tank must also be included.





Self-adhesive panels

2794



Non-adhesive panels

2795



Aluminium tape

2796

Your life onboard will be more comfortable with QL Sound Absorbent Panels. A quieter passage will give you more peace and harmony at sea.

QL Sound Absorbent Panels effectively muffle engine noise. The insulation panels have a density of 100 kg/m³, which is just the right weight to absorb marine engine noise frequencies and noise levels.

They are made of recycled foam plastic, which has a combination of weight and porosity that both insulates and absorbs. Two types are available, with or without self-adhesive pads.

QL Sound Absorbent Panels meet the fire safety requirements for CE marking. The insulation material is protected by an oil-resistant film that is easy to clean. The foam plastic is impregnated to make it self-extinguishing, and to withstand a max. temperature of 200° C.

The insulation is sold in rectangular panels: 500 x 1000 mm, which are light to transport and to apply. They are available in three thicknesses, 20, 30 and 50 mm, and can easily be cut to shape with a sharp knife.

It is important to fit the panels tightly together, using adhesive tape to seal the joints to prevent noise leakage, or penetration of water, which could be absorbed by the material.

Material: Recycled polyurethane foam
 Density: 100 kg / m³
 Protection film: Aluminium foil ISO3795
 Fire proof reg: (FMVSS302)
 Temperature resistance: 200° C.
 Oxygen index: 24 % according to ASTM D2863-91

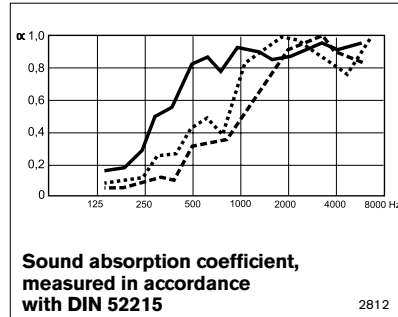

Sound absorbent panel	Dimensions	Rear side	Part no.
20 mm	500x1000 mm	Non-adhesive	41103800-3
30 mm	500x1000 mm	Non-adhesive	41103801-1
50 mm	500x1000 mm	Non-adhesive	41103802-9
20 mm	500x1000 mm	Self-adhesive	41103803-7
30 mm	500x1000 mm	Self-adhesive	41103804-5
50 mm	500x1000 mm	Self-adhesive	41103805-2
Aluminium tape			
Roll	5 m	Self-adhesive	41103806-0
Roll	50 m	Self-adhesive	41103807-8





QL Windlass

2472

A windlass simplifies lowering and raising the anchor. At the push of a button the windlass raises the anchor when it is time to cast off. An active pressure roller grips the anchor line whatever the load. This solves the problem of slipping anchor line. Even if the anchor line becomes slack the windlass will still pull in the line.

WINDLASS

Part no.: 41100501-0

The windlass has a patented design. Lead line is used with the windlass. It has all the advantages of chain, but is easier to handle and stow away. The windlass is designed for bow and stern installation. It can be installed inside or outside on most sail boats and motor boats. The windlass can be operated by remote control. This allows slack in the anchor line to be taken up from land. The windlass is CE approved. For the complete windlass the following are required:

Internal installation: Windlass + control panel or remote control.

External installation: Windlass + cover + control panel or remote control.

Voltage: 12 V
 Motor rating: 1000 W
 Traction: 350 kg
 Winch speed: 20–25 metres per minute
 Weight: 14.5 kg

ANCHOR MOUNTING

Part no. 41100504-4

For installation on bathing platform. Stainless, acid-resistant steel.

ANCHOR MOUNTING

Part no. 41100503-6

For stern installation. Adjustable to various angles. Stainless, acid-resistant steel.

ANCHOR MOUNTING

Part no. 41100532-5

For Bruce anchor, max. 15 kg. Stainless, acid-resistant steel.

CONTROL PANEL

Part no. 41100531-7

Including cable.

ANCHOR LINE

Part no. 41100519-2

16 mm lead line, 50 m. Braided. 0.4 kg per metre.

REMOTE CONTROL

Part no. 41100505-1

Additional duct for deck lighting, etc. Approved by PTS.

FUSE

Part no. 41100506-9

100 A.

BOW ASSEMBLY KIT FOR WINDLASS

Part no. 41100529-1

Through-deck fitting with guide rollers.

COVER FOR EXTERNAL INSTALLATION

Part no. 41100533-3

Including roller.

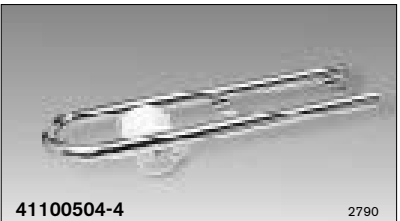

41100504-4

2790

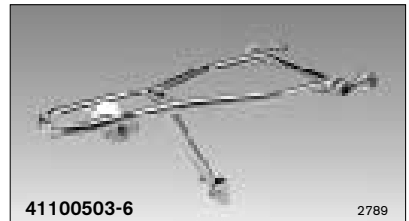

41100503-6

2789



41100532-5

2521

INSTALLATION EXAMPLES

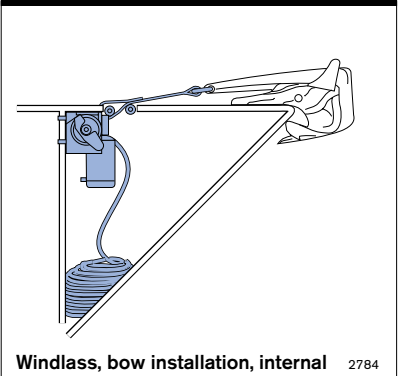

Windlass, bow installation, internal

2784

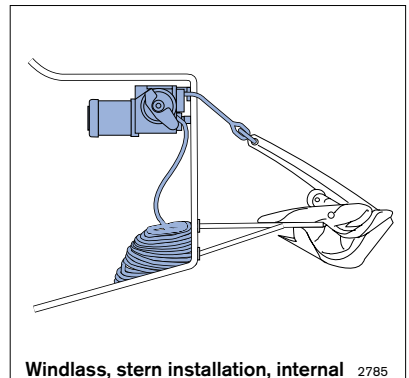

Windlass, stern installation, internal

2785

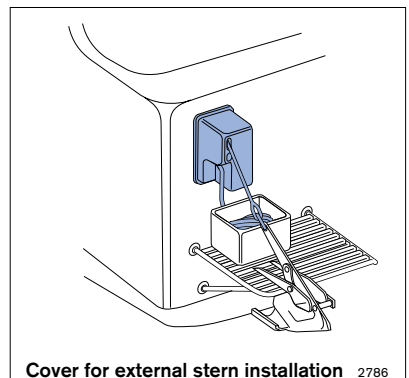

Cover for external stern installation

2786

